

PHILIPPGROUP

PHILIPP Spherical head double-head anchor



VB3-T-065-en - 03/16

Installation and Application Instruction

PHILIPP Spherical head double-head anchor

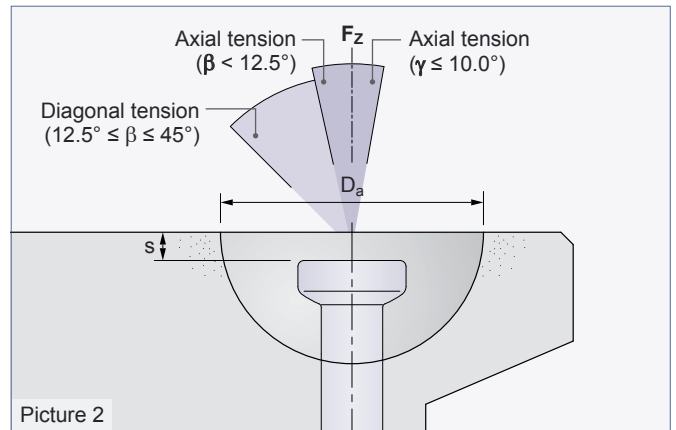
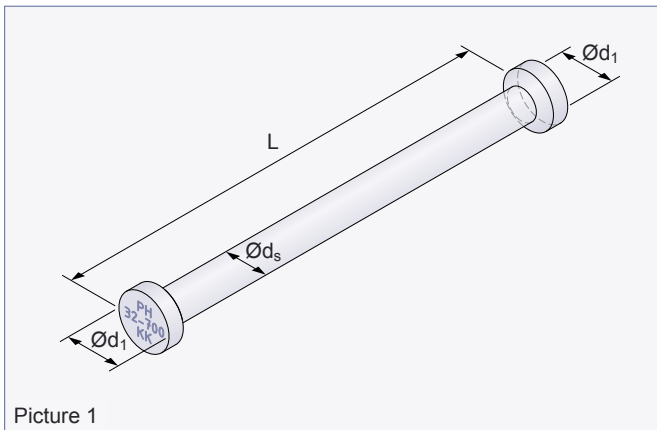

The Spherical head double-head anchor is part of the PHILIPP Transport anchor system and complies with the VDI/BV-BS Guideline "Lifting inserts and lifting insert systems for precast concrete elements" (VDI/BV-BS 6205). The use of Spherical head double-head anchor requires the compliance with this Installation Instruction as well as the General Installation Instruction. The Application Instruction for the belonging PHILIPP lifting device (Spherical head Lifting clutch) as well as the data sheets of the belonging PHILIPP accessories (rubber, steel or magnetic recess formers) must be followed also.

The anchor may only be used in combination with the mentioned PHILIPP lifting devices. Spherical head double-head anchors are designed for the transport of precast concrete units only. Multiple use within the transport chain (from production to installation of the unit) means no repeated usage. This Installation Instruction does not specify a repeated usage (e.g. ballasts for cranes) or a permanent fixation. In order to distinguish the different sizes of Spherical head double-head anchors a marking with load class and anchor length is given on the head of the anchor.

Table 1: Load classes and dimensions

Ref.-No.	Type	Dimensions					Weight [kg/pc.]
		L [mm]	Ød _s [mm]	Ød ₁ [mm]	s [mm]	D _a [mm]	
81-200-500D	KK 20.0	500	38	69	15	160	5.50
81-320-700D	KK 32.0	700	50	88	23	214	13.55

Materials

Spherical head double-head anchors consist of a conforming to standards round steel with a forged head at both ends. The anchor can be supplied also in an electro-galvanised, hot-dip galvanised and stainless steel version.

Application

A Spherical head double-head anchor is especially designed for the transport of concrete beams with a very narrow thickness. Table 2 shows the bearing capacities of the Spherical head double-head anchors.

Corrosion

If the concrete elements with installed Spherical head double-head anchors will be stored outside for a longer time (i.e. contact with rain or humidity causes moisture insight the recesses) an upcoming corrosion may reduce the bearing capacity of the Spherical head double-head anchor. Therefore the anchors may fail under load. In addition, marks on the concrete surface caused by corrosion cannot be avoided totally.

Concrete

Given concrete strengths f_{cc} in table 2 are cube strengths at the time of the first lifting.

Bearing capacities

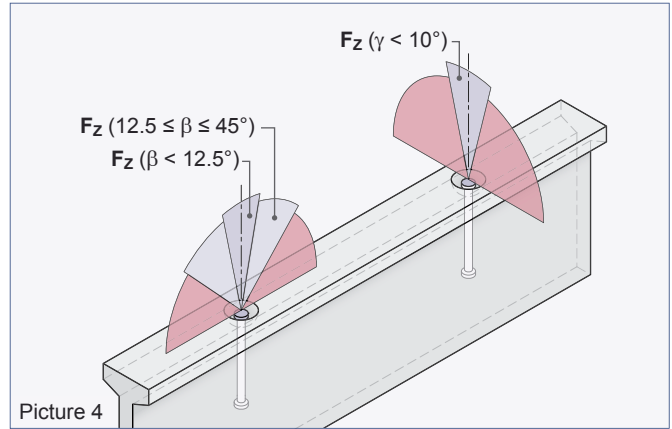
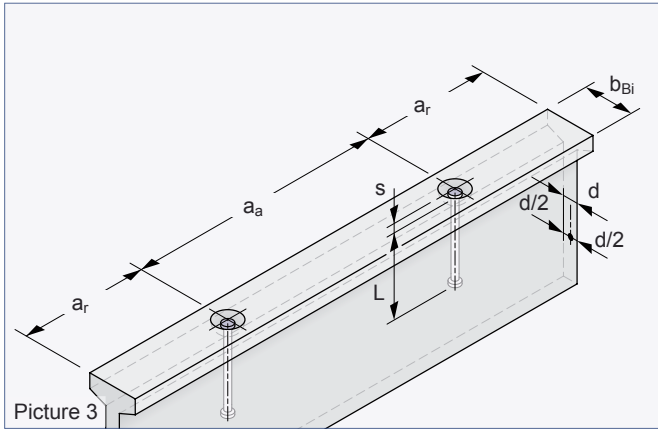

Element thicknesses, centre and edge distances

The position and installation of Spherical head double-head anchors in concrete units require minimum dimensions of precast concrete elements and minimum centre distances for a safe lifting and mounting. Minimum thicknesses d of a unit given in table 2 cover all load directions (axial and diagonal tension).



Lateral tension is not allowed within the whole transport chain.
This also applies to a diagonal tension with angle β more than 45° !

Table 2: Permissible load bearing capacities

Ref.-No.	Load class	Thicknesses and edge distances				perm.F		perm.F		perm.F	
						if f_{cc} is 25 N/mm ²		if f_{cc} is 35 N/mm ²		if f_{cc} is 45 N/mm ²	
						Axial tension	Diagonal tension	Axial tension	Diagonal tension	Axial tension	Diagonal tension
		d [mm]	b_{Bi} [mm]	a_r [mm]	a_a [mm]	perm. F_z 0° - 12.5°	perm. F_z 12.5° - 45°	perm. F_z 0° - 12.5°	perm. F_z 12.5° - 45°	perm. F_z 0° - 12.5°	perm. F_z 12.5° - 45°
81-200-500D	20.0	≥ 400	1400	2000	120	134.5	121.1	159.2	143.3	180.5	162.4
					140	137.8	124.0	165.7	149.1	187.9	169.1
					160	141.1	127.0	172.2	155.0	195.3	175.8
					180	144.4	129.9	178.8	160.9	200.0	182.4
					200	147.7	132.9	185.3	166.7	200.0	189.1
					220	150.9	135.8	191.8	172.6	200.0	195.7
					240	154.2	138.8	198.3	178.5	200.0	200.0
					260	157.5	141.7	200.0	184.4	200.0	200.0
					280	160.8	144.7	200.0	190.2	200.0	200.0
81-320-700D	32.0	≥ 500	1400	2000	120	169.1	152.2	200.1	180.1	226.9	204.2
					140	175.6	158.0	211.4	190.3	239.7	215.7
					160	182.1	163.9	222.7	200.4	252.5	227.3
					180	188.6	169.7	234.0	210.6	265.3	238.8
					200	195.1	175.6	245.3	220.8	278.2	250.4
					220	201.5	181.4	256.6	231.0	291.0	261.9
					240	208.0	187.2	267.9	241.1	303.8	273.4
					260	214.5	193.1	279.2	251.3	316.6	285.0
					280	221.0	198.9	290.5	261.5	320.0	296.5

The weight of 1.0 t corresponds to 10.0 kN.

Reinforcement

The use of Spherical head double-head anchors require a minimum reinforcement in the concrete element (Picture 5). At the first time of lifting the concrete must have a minimum strength f_{cc} of **25 N/mm²**.

Should it be necessary to cut single bars for the installation of Spherical head double-head anchors these have to be replaced by bars of the same diameter, strength and enough lap length according to EC 2.

The user is personally responsible for further transmission of load into the concrete unit.



Existing static or constructive reinforcement can be taken into account for the minimum reinforcement according to Picture 5.

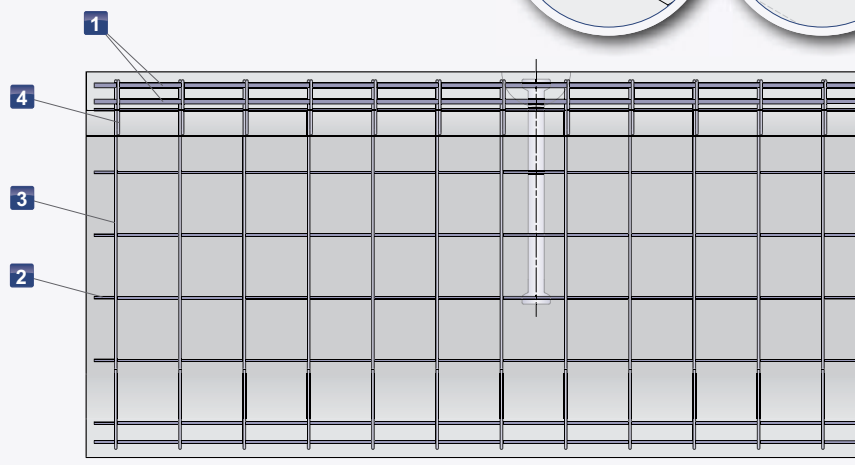
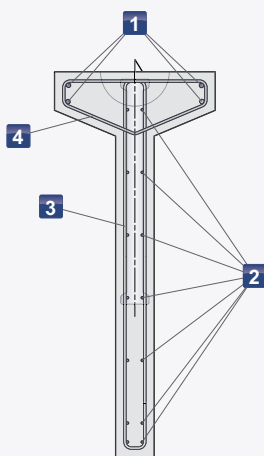
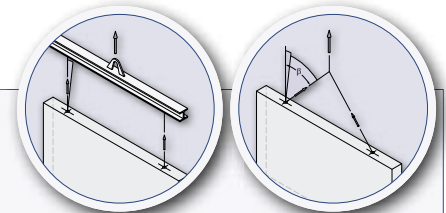

- 1 4 Ø14 (B500A)
- 2 Ø8/200 on both sides (B500A)
- 3 Ø8/200 (B500A)
- 4 Ø8/200 (B500A)

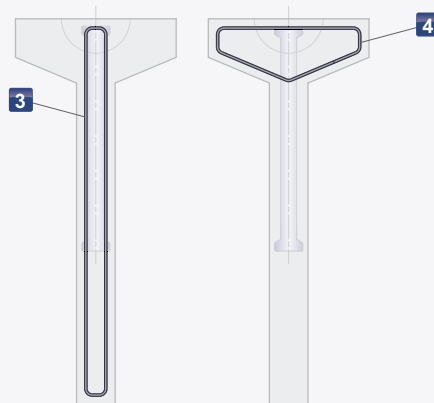

Picture 5 Reinforcement