

# PHILIPPGROUP

## PHILIPP Dowelling system



VB3-V-006-en - 01/16

Data sheet

**PHILIPP Dowelling system**

The Dowelling system is used for the fixation of two concrete units which are stacked. The system consists of a Rebar pocket (Picture 1) for the upper concrete unit, a Concrete pocket (Picture 2) for the lower concrete unit and a steel bolt e.g. steel rebar  $\varnothing 20$  mm, length min. 300 mm. The corresponding holder for the Rebar and Concrete pocket are fixed to the mould by nailing, screwing or hot bonding. Afterwards the pockets are clipped on their fixed holders (Picture 3). Those holders can be removed during demoulding very easily.

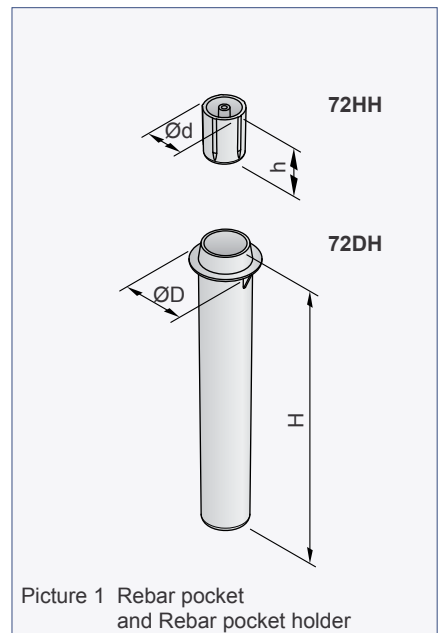

Picture 1 Rebar pocket and Rebar pocket holder

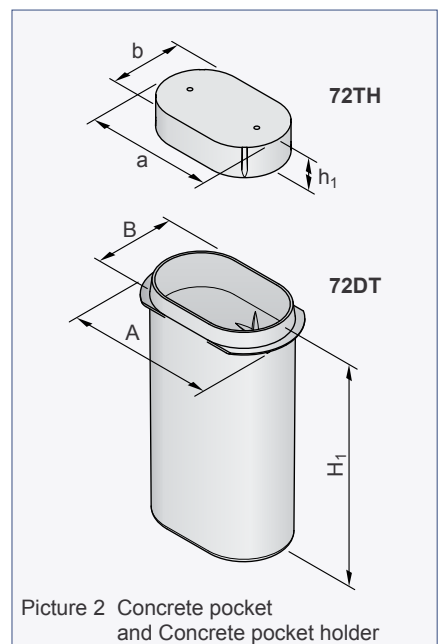

Picture 2 Concrete pocket and Concrete pocket holder

Table 1: Dimension Rebar pocket holder (plastic)			
Ref.-No.	$\varnothing d$ [mm]	h [mm]	Weight [kg/100 pcs.]
72HH	23	30	0.5

Table 2: Dimension Rebar pocket (plastic)			
Ref.-No.	$\varnothing D$ [mm]	H [mm]	Weight [kg/100 pcs.]
72DH	29	180	3.3

Table 3: Dimension Concrete pocket holder (plastic)				
Ref.-No.	a [mm]	b [mm]	$h_1$ [mm]	Weight [kg/100 pcs.]
72TH	80	52	20	1.6

Table 4: Dimension Concrete pocket (plastic)				
Ref.-No.	A [mm]	B [mm]	$H_1$ [mm]	Weight [kg/100 pcs.]
72DT	87	56	150	8.0

**Mounting of the precast units**

For the mounting of the precast units the steel bolt must be inserted completely into the Rebar pocket of the upper unit. Due to the tapering shape of the Rebar pocket a falling out of the steel bolt is prevented. Prior installation the Concrete pocket in the lower unit must be filled with grouting mortar (Picture 4), so that the steel bolt will set into the mortar during lowering of the upper unit (Picture 5). Because of the shape and size of the oval Concrete pocket the elements can be aligned easily and sufficiently.

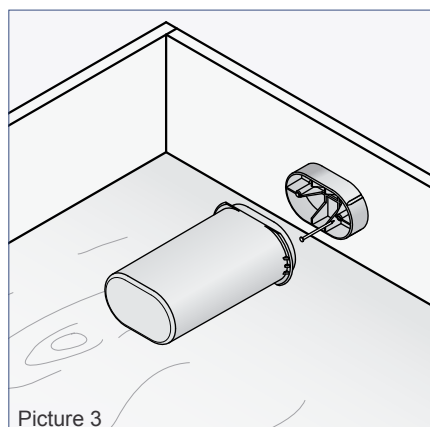

Picture 3

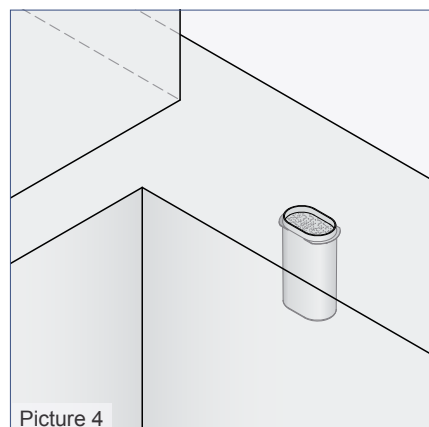

Picture 4

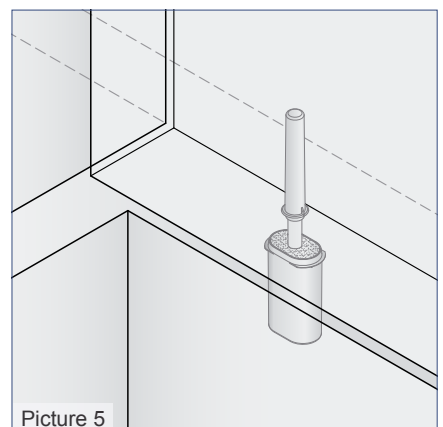

Picture 5